

MINI IMPLANTS

Minicare

DNB NEEDLE
Ball Head Implants

DN NEEDLE
Tapered Head Implants

DN NEEDLE
Tapered Head Implants

DNB NEEDLE
Ball Head Implants

Minicare
minimal care

Minicare
minimal care

WORKS ALONGSIDE
EXISTING SYSTEMS

Denti Mini is not just another implant system – it's a powerful **supplementary tool** that expands clinical possibilities while offering **faster, simpler, and more affordable solutions** to patients.



PREMIUM MATERIALS AND
SURFACE TREATMENT

DENTI NEEDLE-SHAPED IMPLANT SYSTEMS

With the application of Denti® small-diameter implants, patients can benefit from minimally invasive procedures that provide immediate denture stabilization. This enables quick and straightforward solutions for fixed denture retention at an affordable cost.

EASY TO USE,
MINIMALLY INVASIVE,
IMMEDIATELY LOADABLE,
AFFORDABLE

EXPANDS ACCESS TO IMPLANT TREATMENT
SIMPLIFIED SURGICAL PROCESS
FINANCIAL BENEFITS FOR BOTH CLINICIAN AND PATIENT
RELIABLE, DURABLE, AND BIOCOMPATIBLE

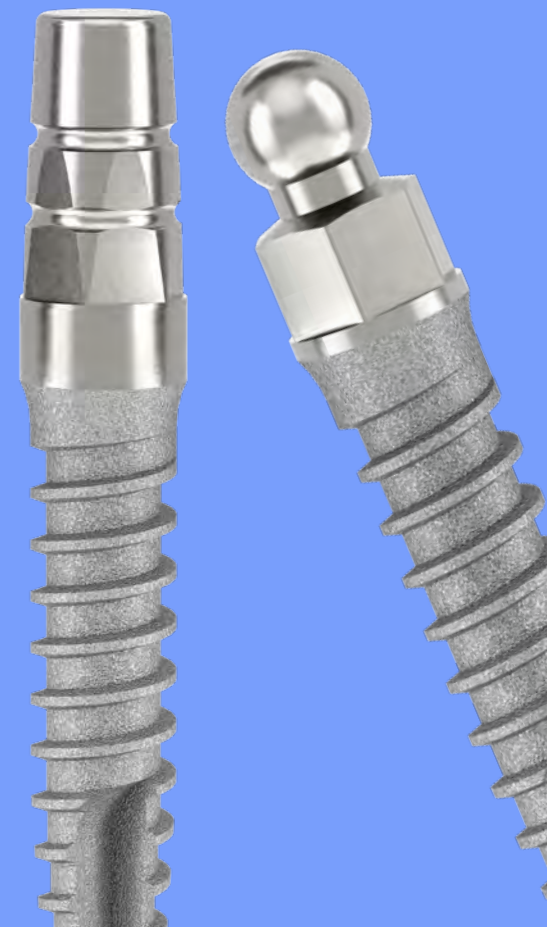

LONG-TERM SUCCESS

The first generation of Denti Diakor needle-shaped implants, made from aluminum oxide bioceramics, was introduced in 1983. By early 1987, the second generation of blade, double-needle, and needle-shaped implants was made from titanium, featuring the unique characteristic of being bendable at the neck area. Two decades later, the tapered and ball-head Denti Needle Implant System was introduced with diameters of 2.3 mm and 2.8 mm.



CLINICALLY PROVEN RESULTS

OVER THREE DECADES OF CLINICAL EXPERIENCE

1983



1987



1987



2009



DNB NEEDLE
Ball Head Implants

DN NEEDLE
Tapered Head Implants

MINIMALLY INVASIVE PROCEDURES

The surgical procedure for Denti Needle Implants is quick and minimally traumatic. Implantation requires minimal bone preparation, significantly reducing the likelihood of postoperative complications. Both the surgical and prosthetic processes are easy to learn, simple, and fast to perform.

Denti Needle Implants are immediately loadable after placement in case of adequate bone quality. They can also be used in cases where the narrow jawbone ridge cannot accommodate two-phase implants due to their larger diameters.



APPLICABLE

TRANSGINGIVALLY, WITHOUT SURGICAL EXPOSURE

FOR DENTURE RETENTION IN BOTH THE MAXILLA AND MANDIBLE

SUITABLE FOR REMOVABLE DENTURES - FOR THEIR STABILIZATION

FOR SIMPLE AND COMPLEX UNITS, INCLUDING BRIDGES AND CROWNS

FAST AND TRAUMA-FREE SURGICAL PROCEDURES

Can also be used as **temporary or permanent support** during the healing period in traditional implant-supported dental restorations. **Simple and fast** to apply.

DESIGN

CLINICALLY
PROVEN RESULTS

The body of the Denti Needle Implants is root-shaped, resembling the natural tooth root. Thanks to their specialized threading, the implants exhibit a high bone-condensing effect, ensuring perfect primary stability, even in **D3 bone quality**. Their insertion is facilitated by self-tapping edges.



The **2.3 mm** diameter Denti® Needle Implants are primarily recommended for **D1** and **D2** bone quality.

The **2.8 mm** diameter Denti® Needle Implants are primarily recommended for **D2** and **D3** bone quality.



D1

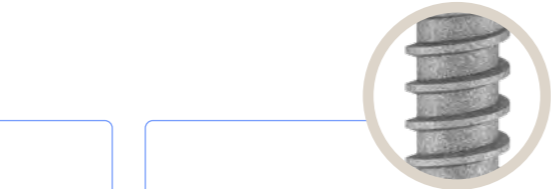

D2



D3



SURFACE

MICROPOROUS,
HYDROPHILIC SURFACE

The surface of Denti Needle Implants is identical to the proven Denti implants, which boast a success rate exceeding **98.75%**. The implant body that contacts bone tissue has a microporous, hydrophilic surface achieved through physical and chemical surface modifications. This design provides high surface energy, ensuring the rapid and secure formation of hard tissue and long-lasting stability on the Denti implant surface.



SUCCESS RATE EXCEEDING

98,75%

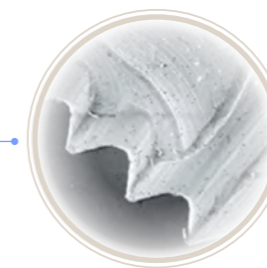

Raw processed surface

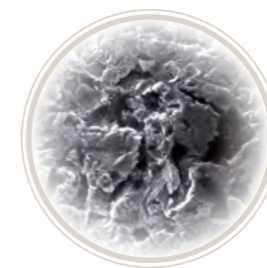

Sand-blasted surface

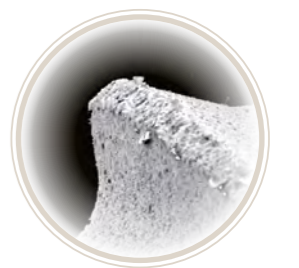

Passivated surface

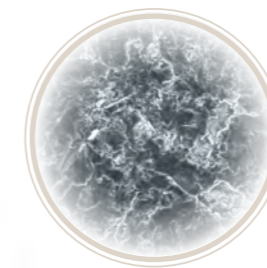

Surface microstructure of Denti implants (MPS, SEM 500x)



Surface microstructure of Denti implants (MPS, SEM 10.000x)

TYPES AND SIZES

NEEDLE-SHAPED IMPLANT WITH TAPERED HEAD

The Denti® Needle Implant Systems are available in **two diameters** and **three different lengths**, with **two distinct head designs**.

Reference Number	Implantation Length	Total Length
N 12311	11 mm	18 mm
N 12313	13 mm	20 mm
N 12315	15 mm	22 mm
N 12811	11 mm	18 mm
N 12813	13 mm	20 mm
N 12815	15 mm	22 mm

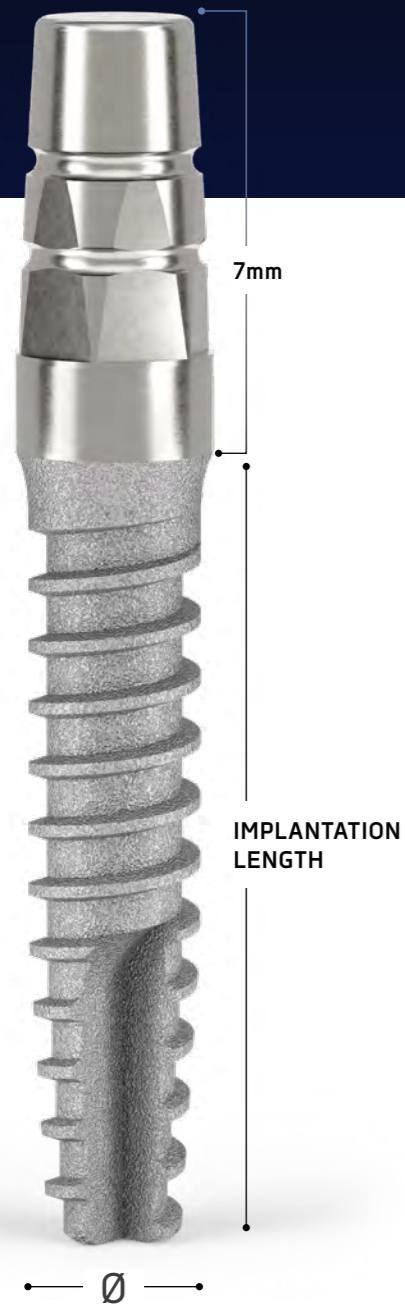

DN NEEDLE Tapered Head Implants

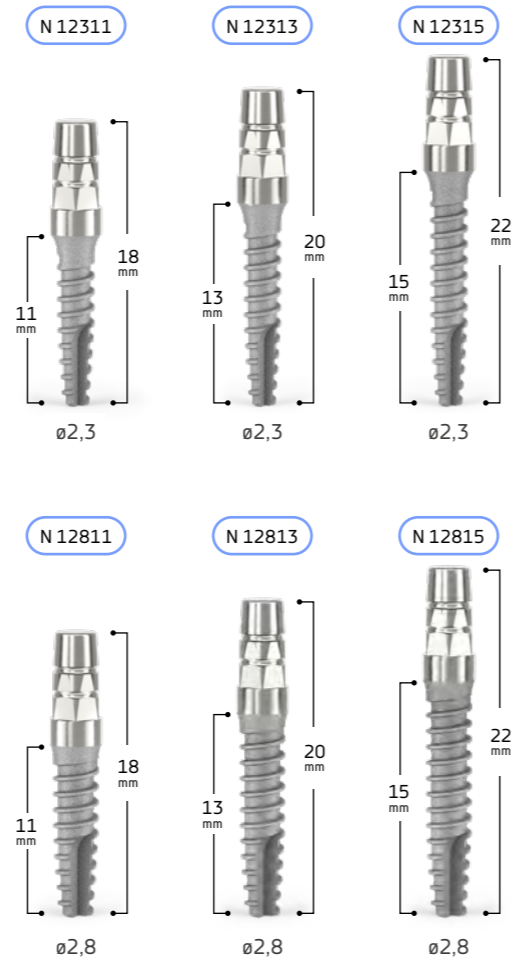

TYPES AND SIZES

NEEDLE-SHAPED IMPLANT WITH BALL HEAD

OT CAP
compatible

Reference Number	Implantation Length	Total Length
NB 12311	11 mm	16 mm
NB 12313	13 mm	18 mm
NB 12315	15 mm	20 mm
NB 12811	11 mm	16 mm
NB 12813	13 mm	18 mm
NB 12815	15 mm	20 mm

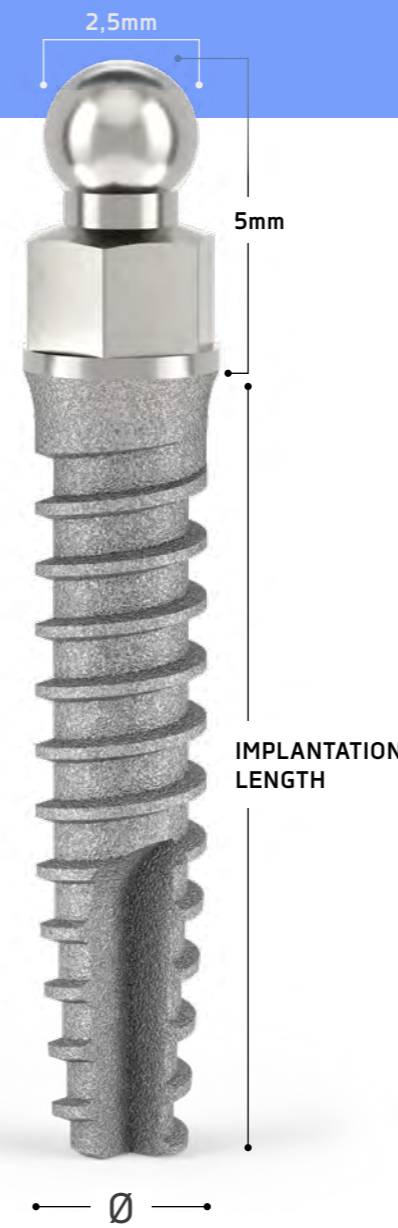

DNB NEEDLE Ball Head Implants

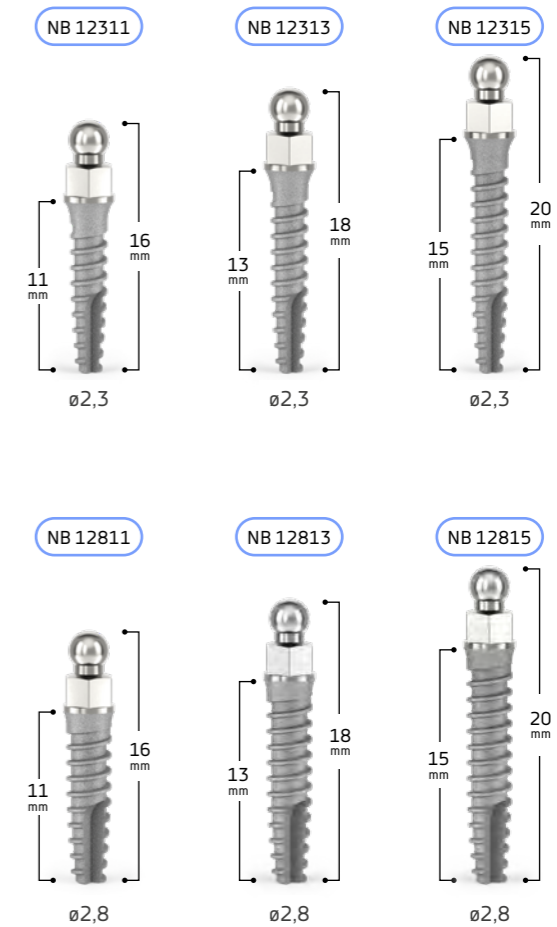

SURGICAL EQUIPMENT

SURGICAL TRAY FOR DENTI NEEDLE IMPLANTS

The Denti® Needle Implant System includes a specialized surgical kit containing all the instruments necessary for surgical and prosthetic procedures. The surgical kit for the Denti® Needle Implant System is easy to navigate, ensuring fast, efficient, and hassle-free implant placement.

The same surgical instruments are used for both head designs (tapered and OT-CAP-compatible ball head).



REF. NUMBERS	
8000-067	Initial Drill
40018	Pilot Drill for Ø 2.3 mm Denti® Needle Implants
N 80028	Pilot Drill for Ø 2.8 mm Denti® Needle Implants
N 8000-079	Driver with power drive
8000-143	Torque-Limiting Ratchet Wrench
8000-002	Driver Manual

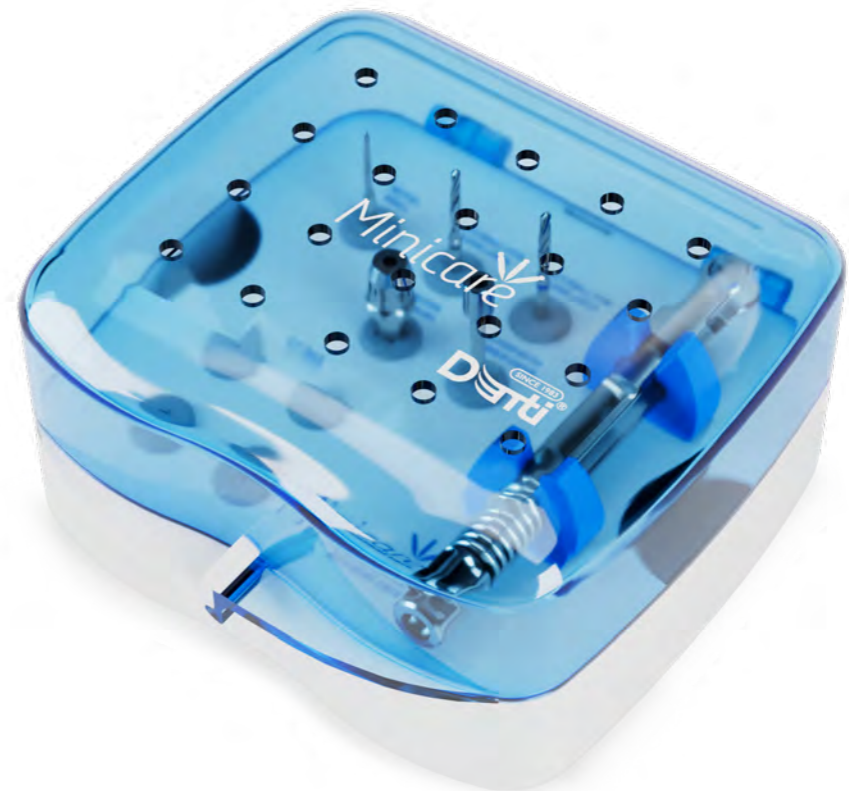

SURGICAL EQUIPMENT

SURGICAL INSTRUMENT SET FOR DENTI NEEDLE IMPLANTS

Tools for accurate and efficient insertion:

Initial Drill: Used to precisely mark the implant site.

Pilot Drill: The pilot drill prepares the core hole for the implant.

Select the appropriate drill diameter based on bone quality.

Recommended speed: 800-1200 rpm

PACKAGING

The implants are supplied sterilized with gamma radiation. Prosthetic components and instruments must be sterilized in an autoclave prior to use.



DN NEEDLE
Tapered Head Implants

DNB NEEDLE
Ball Head Implants

Manufacturer	Sterilized using irradiation
Use-by date	Do not resterilize
Date of manufacture (year, month)	Do not use if package is damaged
Size: Diameter (mm)	Keep away from sunlight
Size: length (mm)	Keep dry
Batch code (lot number)	Consult instructions for use
Catalogue number (reference number)	Caution
CE 2409 CE mark	Rx only United States Federal law restricts medical devices to sale by or on the order of a licensed healthcare practitioner
Do not reuse	

PROSTHETIC COMPONENTS

For **ball-head Denti® Needle Implants**, direct impression-taking is recommended. The **tapered-head Denti® Needle Implant** can tolerate minor angulation corrections (up to 7°) without preparation.



REFERENCE NUMBERS	COMPONENTS AND ACCESSORIES
N 3232884	Impression Cap for Ø 2.3 mm and Ø 2.8 mm Denti® Needle Implants
N 3232887	Laboratory Analog Implant for Ø 2.3 mm and Ø 2.8 mm Denti® Needle Tapered Head Implants
NB 3232887	Laboratory Analog Implant for Ø 2.3 mm and Ø 2.8 mm Denti® Ball Head Implants
041CAN	OT-CAP metal housing
040CRN	OT-CAP retaining cap standard
040CRNSN	OT-CAP retaining cap soft
049PCN	OT-CAP retaining cap hard
040CRNDR8	OT-CAP retaining cap extra hard

IMPLANT SURGICAL PROTOCOLS

DN NEEDLE
Tapered Head Implants

DNB NEEDLE
Ball Head Implants

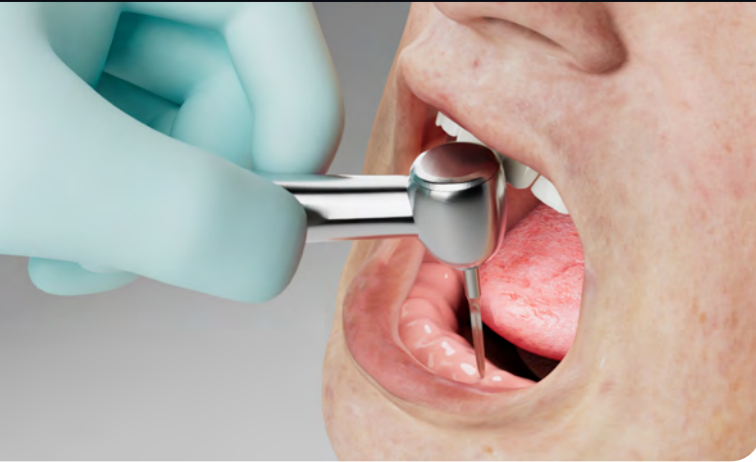

1. Marking the Implant Site

The placement site of the implant is marked transgingivally using the **scoring drill (8000-067)**. This ensures that in the next step, the corresponding **pilot drill** remains stable in the bone and does not slip.



2. Preparing the Implant Site



For implants with a **2.8 mm** diameter, use the pilot drill marked with code **N 80028**

N 80028



For implants with a **2.3 mm** diameter, use the pilot drill marked with code **40018**.

40018

Drilling Depth Recommendations Based on Bone Quality

D1 bone quality: Drill to **2/3** of the threaded length of the implant.

D2 bone quality: Drill to **1/2** of the threaded length of the implant.

D3 bone quality: Drill to **1/3** of the threaded length of the implant.

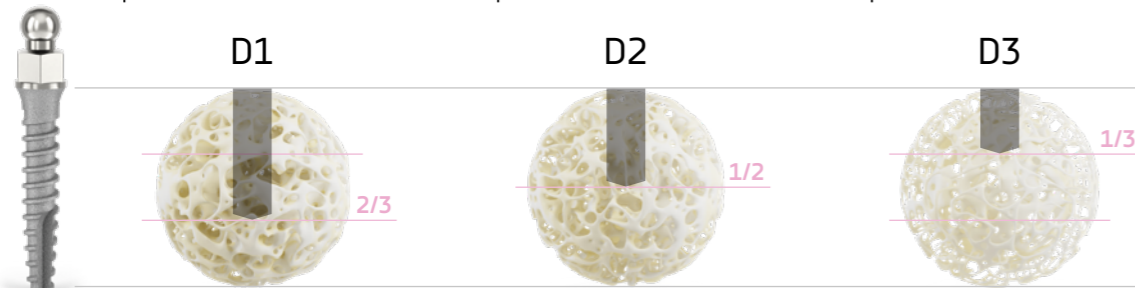

Important: Always perform drilling with intensive irrigation. Recommended speed: **900 - 1200 RPM**

The **Denti Needle implants** are equipped with **self-tapping threads**, eliminating the need for separate thread-cutting.

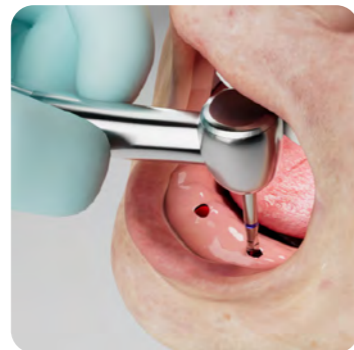

This initial osteotomy will define the **final angulation of the implants**, so it is **essential to maintain parallelism** between them.

3. Implant Placement

Open the sterile packaging of the Denti Needle implant.



Using the **implant holder**, remove the implant and begin insertion into the prepared osteotomy. The holder is suitable for the initial few turns of the implant.



Once the implant has achieved **primary stability** in the bone, gently detach the holder and proceed with one of the following methods:

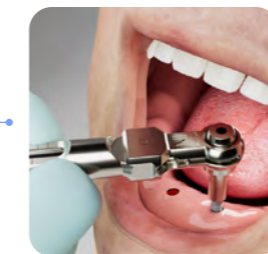
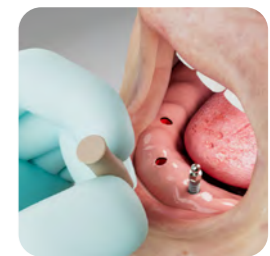

b. Attach the **Manual Driver (8000-002)** and continue insertion using a **ratchet (8000-143)** with **slow, controlled movements**, also limited to a **maximum of 45 Ncm torque**.

8000-002

8000-143



a. Attach the **Driver with Power Drive (N 8000-079)** and continue insertion using a **contra-angle handpiece** at low speed, applying a **maximum torque of 45 Ncm**,

N 8000-079



Continue insertion until the entire treated surface of the implant is within the bone, with only the **polished collar** remaining visible.

For **immediate loading**, a minimum insertion torque of **35 Ncm** is required.

If **45 Ncm torque** is insufficient for full insertion, the implant must be **removed** and the osteotomy **deepened** to preserve bone tissue integrity.

1. Placement of Impression Caps

Snap the impression caps directly onto each Denti Needle implant.

Note: The impression cap included in the system is compatible with all types and sizes of Denti Needle implants.

(3232884 Impression cap)

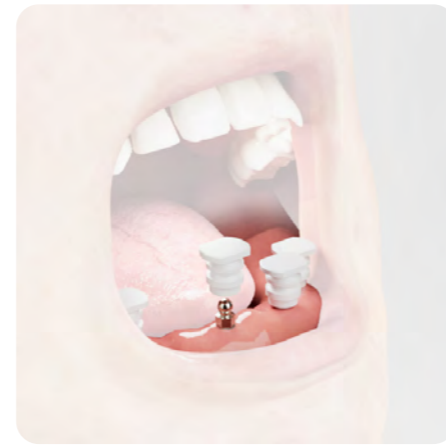
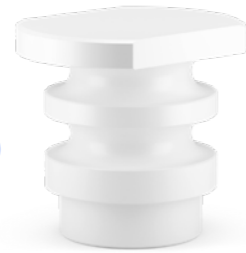

For Ball Head Implants and Tapered Head Implants

4. Placement of Laboratory Analogs

Ensure that you are using the correct Denti Needle laboratory analogs, depending on the implant type used:

- Denti Needle Tapered Head Implants: Laboratory Analog Implant for DN, N 3232887
- Denti Needle Ball Head Implants: Laboratory Analog Implant for DNB, NB 3232887

Insert one analog into each impression cap, then prepare the impression for plaster model fabrication.



N 3232887

NB 3232887

For Ball Head Implants and Tapered Head Implants

2. Taking the Impression

Use standard impression techniques to ensure that the impression caps are accurately captured and retained within the impression material.

Recommended material: Polyether impression material – ideal for high-precision implant impressions.

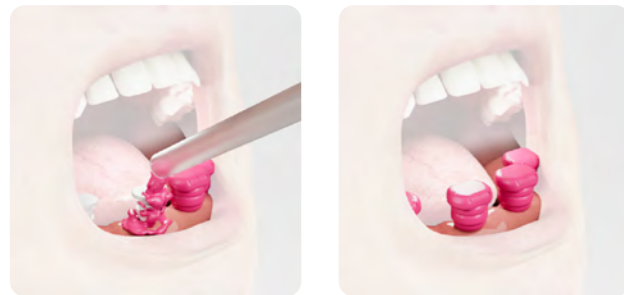

3. Removing the Impression

Once the impression material has fully set, carefully remove the impression tray from the patient's mouth.

Check to ensure that all impression caps are securely embedded in the impression.

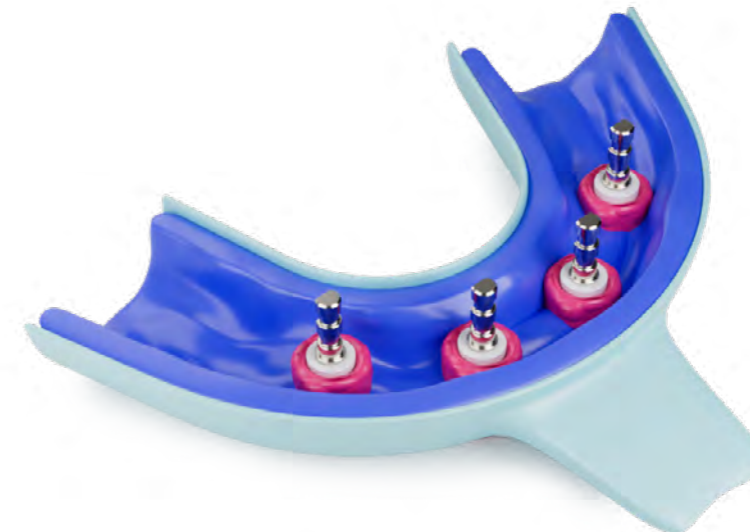
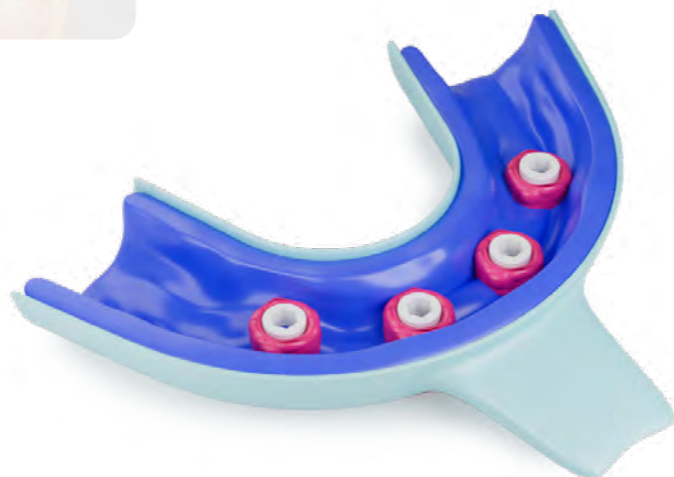

5. Fabrication of the Plaster Model

Use standard dental laboratory techniques to pour the plaster model. Once the plaster has fully set, carefully remove the impression from the model.



For Ball Head Implants and Tapered Head Implants



Reference Number	Implantation Length	Total Length	Diameter
N 12311	11 mm	18 mm	ø2,3mm
N 12313	13 mm	20 mm	ø2,3mm
N 12315	15 mm	22 mm	ø2,3mm
N 12811	11 mm	18 mm	ø2,8mm
N 12813	13 mm	20 mm	ø2,8mm
N 12815	15 mm	22 mm	ø2,8mm

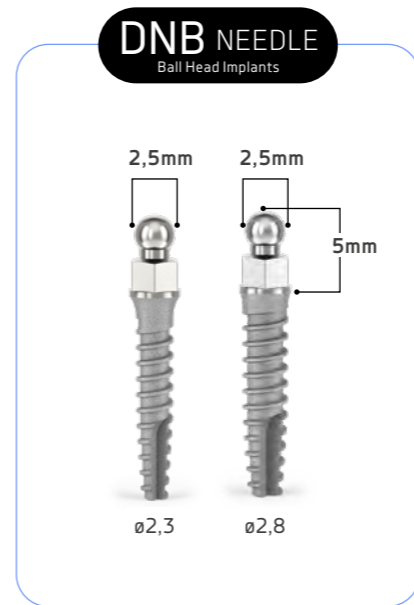

Reference Number	Implantation Length	Total Length	Diameter
NB 12311	11 mm	16 mm	ø2,3mm
NB 12313	13 mm	18 mm	ø2,3mm
NB 12315	15 mm	20 mm	ø2,3mm
NB 12811	11 mm	16 mm	ø2,8mm
NB 12813	13 mm	18 mm	ø2,8mm
NB 12815	15 mm	20 mm	ø2,8mm

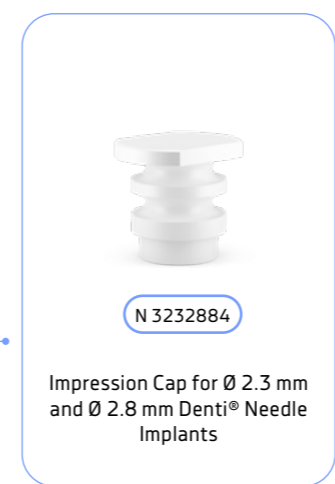

3000-881
OT-CAP metal housing

3000-880
OT-CAP retaining cap standard

3000-881
OT-CAP metal housing

3000-882
OT-CAP retaining cap soft

3000-881
OT-CAP metal housing

3000-883
OT-CAP retaining cap hard

3000-881
OT-CAP metal housing

3000-884
OT-CAP retaining cap extra hard

Minicare

DenTi System Kft.
6600 Szentes, Bese L. u 8. Magyarország



dentisystem.com



minicareimplant.com



callusimplants.com